



High Performance Software Defined Radio
Open Source Hardware and Software Project
Project Description: <http://openhpsdr.org>

PennyWhistle **Assembly and Operation** **Instructions**



Author: Graham Haddock, KE9H

Contents

<i>Introduction</i>	3
<i>Description</i>	3
<i>HPSDR SetUp</i>	4
<i>PennyWhistle Adjustment</i>	6
<i>PowerSDR Settings</i>	6
<i>Assembly Instructions</i>	8

Appendix "A" Schematic and Board Top View

Appendix "B" Comments on hand assembly of SMT components

Appendix "C" Bill of Materials.

Appendix "D" Special sort of the Bill in recommended assembly order.

Appendix "E" Instructions for winding the two transformers.

Appendix "F" Mechanical and PA Transistor Assembly.

Introduction

PennyWhistle is a compact RF power amplifier that can be used with Penelope and Alex to make a complete 16 Watt PEP Linear or 20 Watt saturated CW transmitter. This amplifier can quickly and inexpensively be used to get an HPSDR on the air, either barefoot, or as a driver for a larger linear. It covers the same 160 Meter through 6 Meter bands as the rest of HPSDR.

It is 10 cm by 8 cm (half Euro-board size.)

This amplifier requires an appropriate low pass filter between the amplifier's output and the antenna, to suppress any spurious harmonic signals generated by the amplifier. The low pass filter bank in ALEX is an example of an appropriate low pass filter system. This amplifier will not meet regulatory requirements for spurious emissions without such a low pass filter.

When used as a driver for a higher power PA, the low pass filter system in the High Power amplifier will generally provide the necessary filtering for the entire system.

Description

The amplifier has a single push-pull output stage that uses a pair of TO-220 “15 Watt” Mitsubishi RD16HHF1 or RD15HVF1 parts, and has approximately 19 dB gain, so it will deliver 16 to 20 watts output with about one-fourth to one-half Watt drive.

The amplifier is quite linear when operated at output levels of 16 Watts or less. So, in SSB, or any modes where the amplitude levels of the transmitted signal must be preserved, the amplifier should not be driven above 16 Watts peak power output. In services such as CW or FM, where there is a constant level envelope, the amplifier may be driven harder, up to 20 Watts output, saturating the output stage. Recommended setup with HPSDR is described in a following section.

It can be mounted with a heat sink inside of the Pandora housing. We need to extract about 20 to 25 watts of heat when transmitting continuously. Dissipation in standby is negligible. The circuit is capable of continuous duty, provided that the heatsink is big enough to hold a reasonable temperature.

The two output transistors are actually mounted underneath the PC board, with their heat sink tabs bolted to the main heatsink.

The PCB is mounted to the main heatsink with ¼ inch long #4-40 spacers at four locations in the vicinity of the PA transistors. The leads from the transistors are bent upwards and through the PCB and soldered from the top. Holes in the PCB allow

unbolting the transistors from the main heatsink if needed, without having to unsolder anything.

In the normal 16/20 Watt application, the feedback winding on T2; R2, R12, would not be populated. They are only used if you want to reduce power output, by using negative feedback, to some lower level. So they are there only as an option for special applications.

HPSDR SetUp

The heatsink has two #6-32 threaded holes in the side edge, to allow for mounting in Pandora. You will need to drill two holes exactly 2.0 inches (50.8 mm) apart in the bottom of Pandora, at the location you choose for PennyWhistle.

Pennywhistle requires 12 to 14 Volts at up to 3 Amperes current. A mating connector for the 13.6 Volt (nominal) power has been provided. If the LPU is installed, it may be taken from the location for J6/J7 or J8/J9 on the LPU.

The input BNC coax connector is normally connected to the BNC output on Penelope. The output BNC connector is normally connected to the "From Transmitter" BNC connector on ALEX, or whatever transmit low pass filter you are using. See the Connection Diagram on Page 5.

The 13.6 Volts is continuously connected to the drains of the RF power amplifier transistors. The amplifier is turned on and off by applying and removing the bias on the gates of the transistors.

This bias is controlled by grounding the center pin (Pin 2) of the PennyWhistle control connector J1.

In normal operation, Penelope controls this bias by connecting J1-Pin 1 (Ground) on PennyWhistle to Pin 21 (Digital Ground) on Penelope's DB-25 connector and J1-Pin 2 (Bias Control) on PennyWhistle to Pin 13 (PTT Out) on Penelope's DB-25 connector. [J1-Pin 3, (13.6 Volts) is not normally used or needed.] When you assemble the mating connector for J1, please double check that you have not attached the ground lead or bias control lead from Penelope to the 13.6 Volt pin.

There should be some kind of fuse or current limiting device for the entire system. Since the PennyWhistle will draw slightly less than 3 Amperes at maximum output, a 5 Amp Fuse would be appropriate.

Connection Diagram:

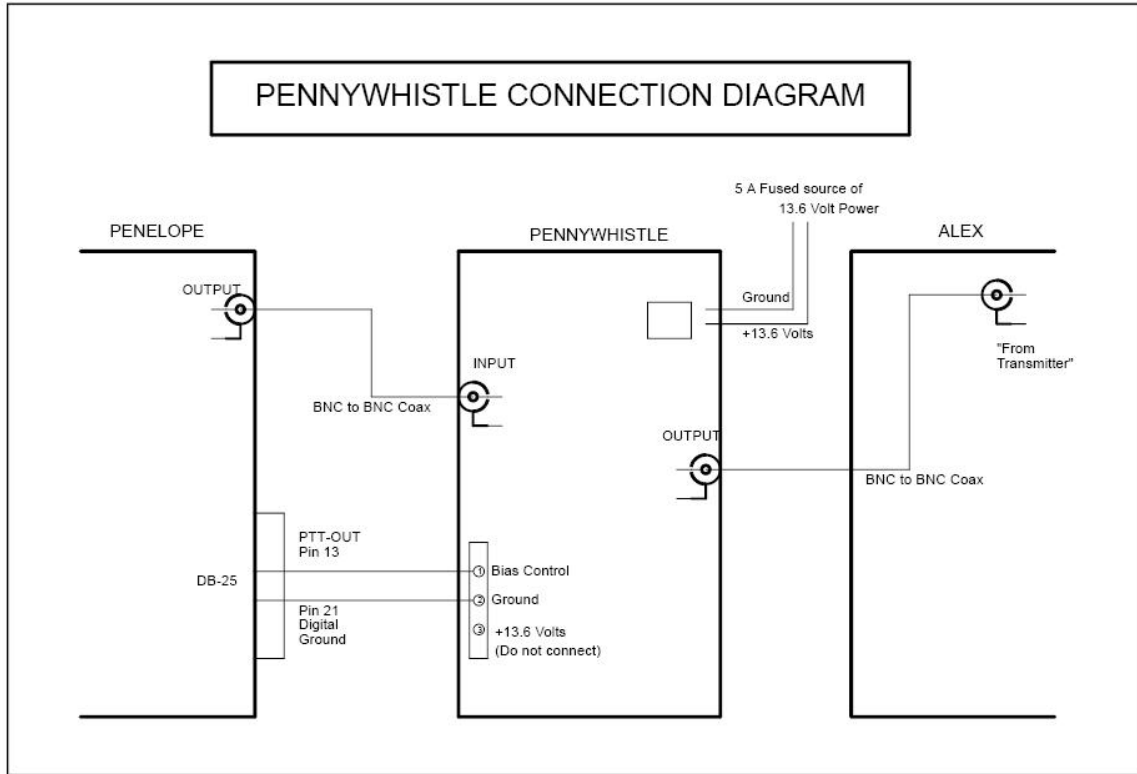

PennyWhistle Adjustment

Pennywhistle is a wide band amplifier, that will amplify signals from 1.8 MHz to 54 MHz without any tuning. The only adjustment is to set the quiescent bias currents on the two amplifier transistors. Each has a separate potentiometer for this adjustment.

- 1.) Turn the two pots fully counter clockwise. (Anti-clockwise for those who speak “English.”)
- 2.) Connect a 50 Ohm dummy load to the output BNC connector. [Should not be needed, but protection just in case some RF input shows up during this adjustment.]
- 3.) Put an ammeter capable of reading more than 3 Amperes DC in series with the +13.6 Volt power to the amplifier.
- 4.) With no RF drive signal, ground the bias control J1-Pin 2. PA current should rise from zero to about 20 mA, which is the bias supply and regulator turning on.
- 5.) Turn one of the pots clockwise until PA current rises to 470 mA. (An increase of 450 mA.) Turn the second pot clockwise until the total PA current rises to 920 mA. (A second increase of 450 mA.) Each transistor is now drawing 450 mA quiescent current.
- 6.) Remove the ground from J1-Pin 2, and connect the amplifier per the diagram on page 5. The amplifier is now ready for operation.

The quiescent current (no RF drive) on the transistors will rise some with heatsink temperature. Any value up to 550 mA (each) is acceptable. The transistors should be safe at any heat sink temperature up to 80 degrees C, or 176 degrees F, although operation at lower temperatures is recommended.

When bias is off, power drain and dissipation is negligible. When bias is on, but no drive signal, the quiescent current is 920 to 1070 mA. With RF drive, the current will rise up to 2.8 Amperes at maximum power.

Some fuses or current protection (perhaps 5 Amps) should be provided in the power system, recognizing that this amplifier will draw up to almost three Amps in normal operation.

PowerSDR Settings

At the time of assembly, by choosing which value of C11 you install in the PA, you can choose to have your PennyWhistle operate up to 6 Meters (C11 = 180 pF), at the expense of a slight reduction in power at 10 Meters, or have maximum flat power up to 10 Meters (C11 = 330 pF), without 6 Meter operation. Two different settings tables are provided below.

The following assumes that PennyWhistle is being used in conjunction with ALEX.

In PowerSDR >> Setup >> General >> Hardware Configuration
 Check ALEX as present.

In PowerSDR >> Setup >> PA Settings

For each band, enter the following "Gain by Band" settings
 from the "PA Gain" column below, for the PA maximum frequency tuning
 selected at the time of assembly.

Recommended Gain Settings - PA Tuned for up to 6 Meters (C11 = 180 pF)

Band	PA Gain	Linear Drive	Linear Watts PEP	CW Drive	Sat Watts
160	40.5	50	16	100	20
80	41.6	50	16	100	20
60	41.6	50	16	100	20
40	41.6	50	16	100	20
30	41.3	50	16	100	20
20	41.0	50	16	100	20
17	40.8	50	15	100	19
15	40.6	50	14	100	18
12	40.4	50	14	100	17
10	39.6	50	14	100	16
6	38.8	100	10	100	10

Recommended Gain Settings - PA Tuned for up to 10 Meters (C11 = 330 pF)

Band	PA Gain	Linear Drive	Linear Watts PEP	CW Drive	Sat Watts
160	41.0	50	16	100	20
80	41.2	50	16	100	20
60	41.3	50	16	100	20
40	41.3	50	16	100	20
30	41.0	50	16	100	20
20	40.5	50	16	100	20
17	39.9	50	16	100	20
15	38.8	50	16	100	20
12	38.8	60	16	100	20
10	38.8	70	16	100	20
6	38.8	100	4	100	5

[Operation on 6M in this configuration not Recommended]

With those settings, at a drive level of 50 in the main PowerSDR window, you will put out 16 Watts PEP on most bands. You may have to increase drive above 24 MHz per

the above tables. Operation above the "Linear Drive" levels will result in amplitude distortion and unacceptable splatter levels for linear operation. For CW or FM operation, you may run the drive setting up to 100 on all bands for maximum output. Note that for a doubling of input power, you are only getting 25 percent more power output, so this is definitely NOT linear operation.

NOTE: To achieve the above power outputs, you should have implemented the output transformer rework on Penelope. Refer to Penelope Errata #1 at

http://openhpsdr.org/support/Penelope/Penelope_Errata.pdf

Without this modification, the amplifier will still work, but input power will be lower, and you may not achieve maximum power output on all bands.

Assembly Instructions

There is one choice to be made, in advance, with respect to capacitor C11, for peak tuning of the output transformer. A value of 330 pF will maximize power output and amplifier flatness up to 10 Meters, or a value of 180 pF will allow operation up to 6 Meters, at the expense of a slight decrease in the power output above 18 MHz. Refer to the tables in the HPSDR Settings section above, for details. Although both capacitor values are provided, only one of the capacitors should be installed.

Recommended Hand Assembly Order

The general order is small to large, center to outside, surface mount first then thru hole last.

Specifically, this is the recommended order:

- 1.) Small common parts - bypass caps
- 2.) Other small capacitors, resistors, diodes, and surface mount.
- 3.) Surface Mount IC.
- 4.) Misc surface mount (Electrolytics)
- 5.) Transformers
- 6.) Misc through-hole parts (pots)
- 7.) Connectors
- 8.) RF Power Transistor/Heatsink assembly

Special assembly notes

- 1.) Electrolytic capacitors C02 and C25 are polarity sensitive. Position per the shaped outline on the PCB silkscreen. The Black marking on the can is negative/ground.

- 2.) Resistors R05, R07, R08, and R09 are NP, "Not Populated." The locations are there for those who might want to add an input attenuator, which not needed with Penelope.
- 3.) Resistors R02, R12, are NP, "Not Populated." Also, the feed back winding on T2 is not wound on T2 in normal operation. These parts are there for those who might want to operate at lower power using negative feedback.
- 4.) Capacitor C11 should be either a 180pF or a 330 pF capacitor, chosen for the maximum frequency of operation of the amplifier. Observe the location at the front of T3 on the Board Top View drawing in Appendix "A". The silkscreen outline will not appear on the PCB, since that area has been solder coated after silkscreen printing. Install this capacitor prior to installing T3.
- 5.) The integrated circuit U1 should be positioned with pin 1 corresponding to the white dot on the PCB. The integrated circuits may be marked with a dot at pin 1, or with a beveled edge corresponding to the side with pin 1, or with a white band at the end with pin 1. If marked with a beveled edge, this corresponds to the double line on the silkscreen. If a band or dot, that end corresponds to the dot on the silkscreen.
- 6.) Q1, Q2, and Q3 are all insulated gate FETs. Observe Anti-Static handling procedures when handling and installing these parts. They are safe once properly installed and soldered on the board.
- 7.) The #6 hardware is used to mount the two RF power transistors. The smaller #4 hardware is used to mount the PCB to the studs mounted in the heatsink. Four at the corners of the heatsink/board, and four in a rectangle pattern surrounding the RF power transistors
- 8.) ERRATA – In some kits, there were four extra 3/16 inch washers included with the kit in error. It was easier to ship with these than to open all the kits and remove them. Discard these four washers, if received.

Appendix "D" is a special sort of the bill of materials in the recommended assembly order. You may print out a copy of Appendix "D", along with the "Board Top View" from Appendix "A" to use as a checklist and aid for assembly.

Refer to Appendix "B" for comments on hand assembly and soldering of SMT components, if you are not familiar with these techniques.

Appendix "A" contains the schematic and Board Top View, showing all part locations. This Board Top View should be used for part locations. Some of the photographs used for illustration are from earlier versions of the board, and the schematic reference number for the parts may have changed. In case of conflict, the "Board Top View" in Appendix "A" should be considered correct, and will correspond to the silkscreen printing on the PC board.

Appendix "E" contains the instructions for installing the inductors and winding the transformers.

Checkout prior to first power application.

A convenient “Ground” connection is the shield of either of BNC connectors, or the ground pin on the power connector.

The unit draws power from the dedicated +13.6 Volt connector. So check for no shorts to ground on the +13.6 Volt power connector pin. Other than a brief capacitor charging (which may take up to a minute on a digital Ohm meter), I show open with a digital Ohm meter.

In particular, make sure that the mounting washer in the vicinity of C22 does not touch the hot end of C22.

Check for no shorts to ground on the output of the +6 Volt regulator. A convenient point is pin 1 of U1, the 78L06 regulator, or the through-hole via at the junction of C12 and pin 1 of U1. I show 1.1K Ohms to ground with a digital Ohm meter.

If you are concerned about your proper assembly of transformer T1, an easy check is to connect an antenna analyzer, such as an MFJ-259 into the input connector (powered off) and you should see a VSWR below 1.5 from 1.8 MHz to 50 MHz, dipping down to 1.2 or lower around 10 MHz.

If no shorts found and things look OK, proceed to “PennyWhistle Adjustment.”

Appendix "A"
Schematic and Board Top View

PENNYWHISTLE - P1.0
 HPSDR 16/20 WATT RFPA
 17 OCT 2009
 Copyright 2009 Graham Haddock, KE9H
 Released under TAPR NCL
<http://www.tapr.org/NCL>

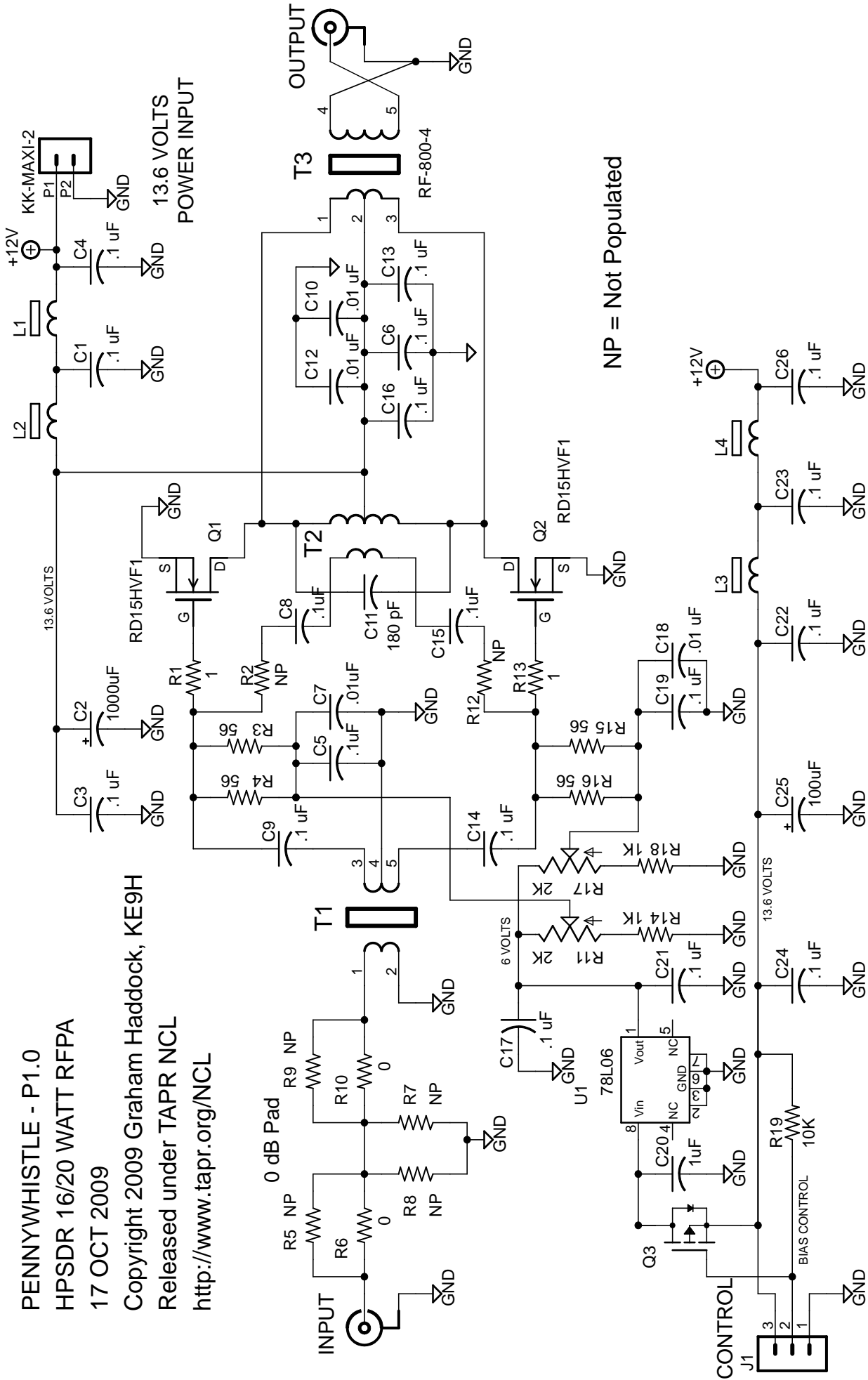

NP = Not Populated

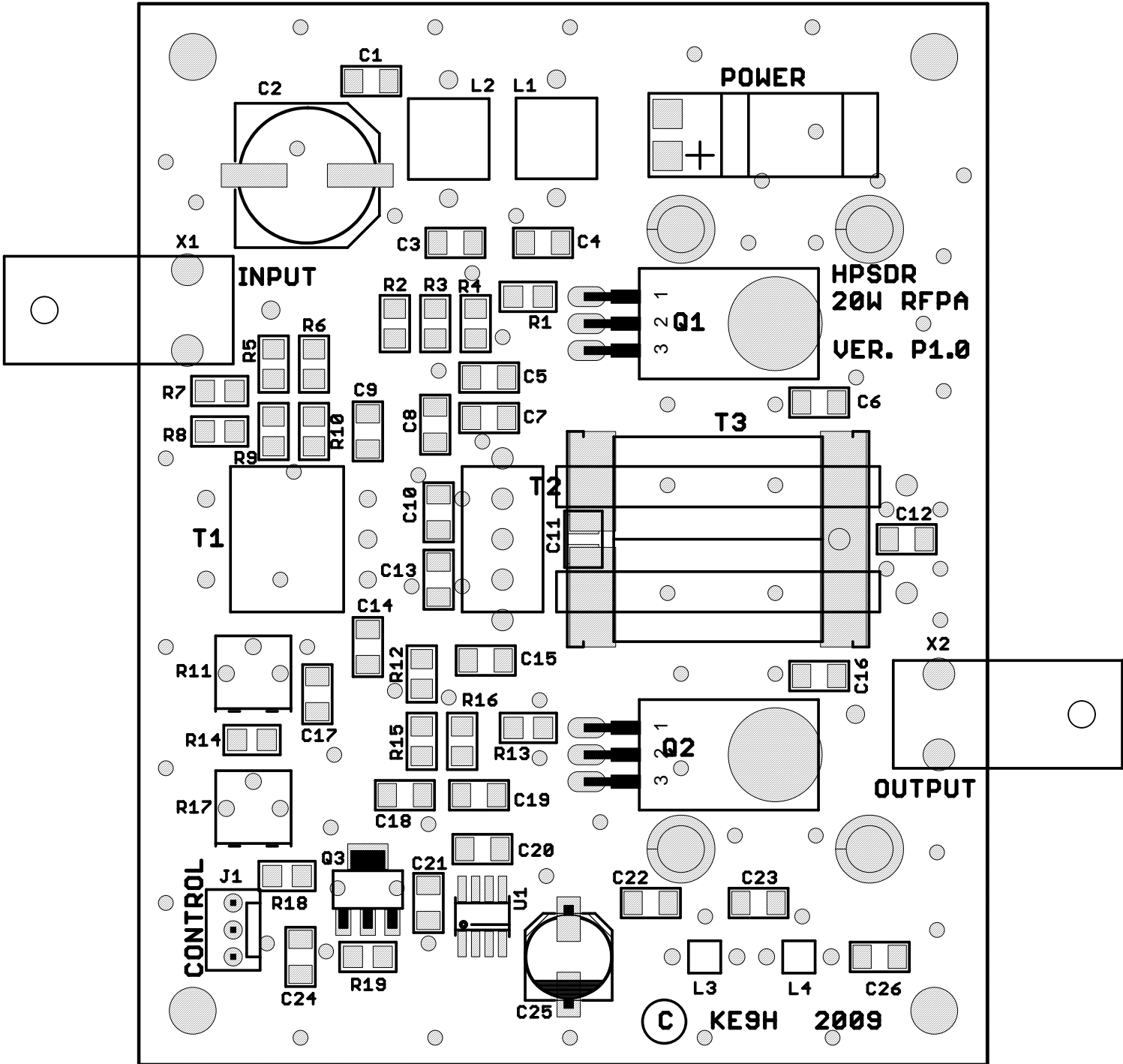

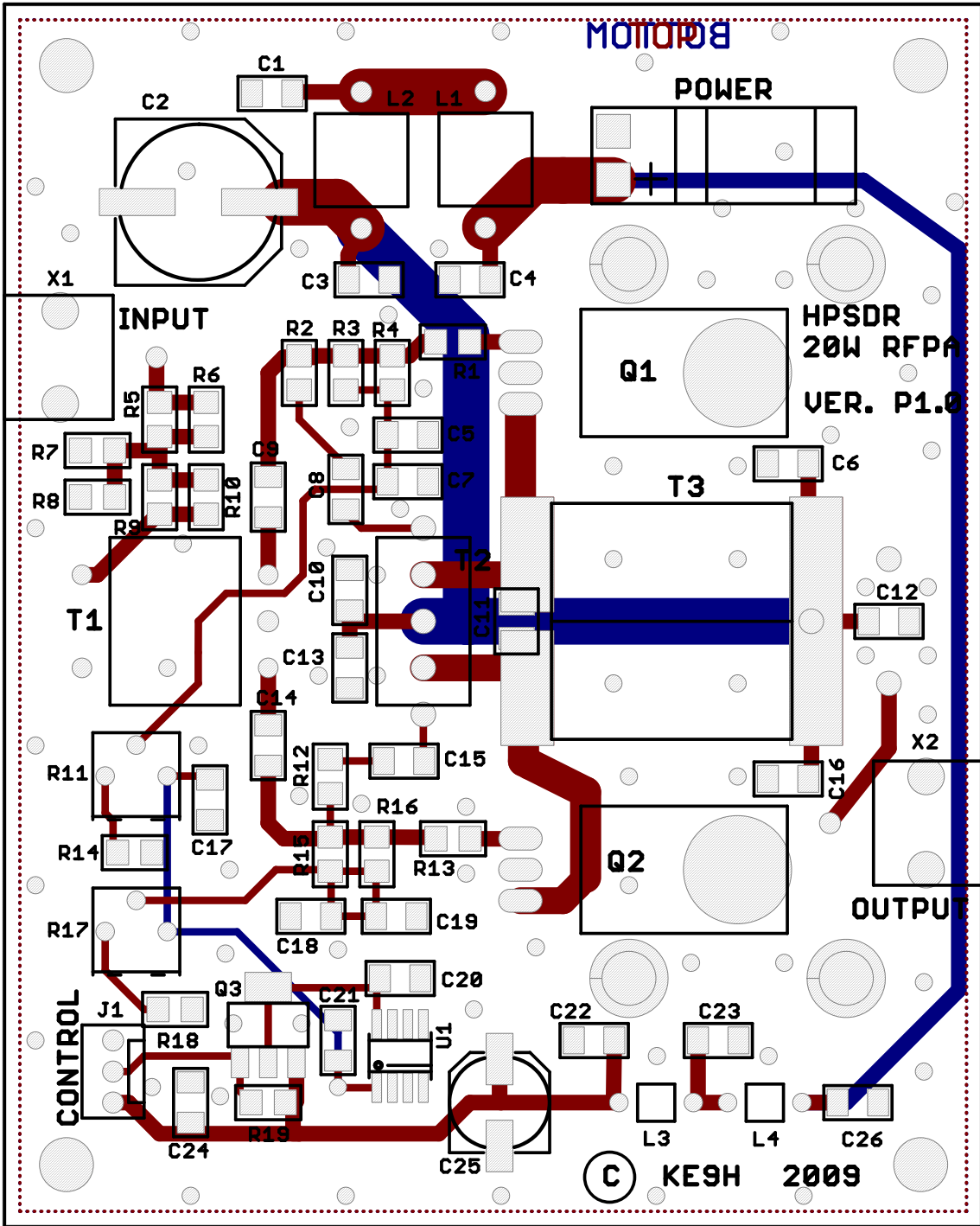

Appendix "B"

Comments on Surface Mount assembly

This appendix is not intended as a tutorial on surface mount soldering, but to give a few highlights. You can find many tutorials on hand soldering SMT components on-line, including YouTube.

This product has about 40 surface mount components, generally using the largest size available, that should make this a good choice for a first kit using surface mount assembly, by hand.

Although it is possible to oven reflow, hot air reflow or hot plate reflow a surface mount PCB, it is not necessary for building this board, and basic hand assembly and soldering will work fine.

Primary tools will be a desk mount lighted magnifying lens, a grounded fine point soldering iron, preferably temperature controlled, and a pair of curved point metal tweezers.

An antistatic work mat with wrist strap is appropriate.

A flux pen is helpful when soldering ICs, as is small diameter solder with a rosin core, and solderwick for picking up any excess solder.

Generally, the process for a capacitor or resistor is to put a small dot of solder on ONE of the pads the part is going to be soldered to. Then, holding the part in the tweezers, hold it in position, and touch the tip of the iron to the solder dot, allowing it to melt and wet the end of the part. Then, using the tip of the tweezer to lightly push down on the center of the part melt the solder again, and the part will "click" down flat against the board. If the part is in the final desired position, melt a tiny bit of solder and fresh flux on the other end of the part, allowing the solder to flow under the end of the part.

If you have a choice as to which end of the part to solder first, the end that is NOT grounded will be easier. Even though this board incorporates thermal reliefs (thermals) on the ground pads, the grounded end will still take more heat to solder than the other end.

For an IC, if you have a flux pen, put a little flux on all PCB pads. Then choose one pad, at a corner, to put a small dot of solder upon. Holding the IC in position with the tweezers, using the iron, melt and solder the one corner pin. If necessary, using the tweezers, and re-melting the solder on the one pin, reposition the IC until it is centered on all pads. Then go to the pin diagonally across the IC and solder it down. If necessary, press down lightly on the center of the IC while re-melting those first two pins, so that all

pins are flat against their respective pads. Then work your way around the IC soldering down all pins. If you have a solder short between adjacent pins, remove any excess solder with "solder wick."

For final inspection, a "Jewelers eye loupe" of approximately 4x power is a great aid. Loupes manufactured in Asia are available on eBay or similar sources for a few dollars.

Additional Thoughts:

There are as many approaches to hand SMT assembly as there are people that have done it. Ask on the HPSDR email reflector if you have a problem. Many will be glad to comment and help and offer alternative ways to do things.

Others have also suggested:

Put one or two sheets of white paper under the board when assembling to increase visibility of dropped parts.

Be sure to keep the tip of the iron clean and coated with non-oxidized solder. This is a particular issue if the iron is not temperature controlled. Damp sponge and fine steel wool (used lightly, don't damage the coating on the tip) are great assistance.

Clip-on eyeglass magnifiers – Harbor Freight # 66825

Micro Flush Cutters – Harbor Freight # 90708

Appendix "C"
Bill of Materials

PennyWhistle P1.04 BOM			Version	10/31/2009										
Part	Value	Description	Footprint/ Package	Library	Manu	Part No.	Vendor	Part No.	Notes					
C01	0.1 uF	Chip Cap C1206	C1206	0G_RCL	Kemet	C1206C104K3RACTU	Mouser	80-C1206C104K3R						
C02	1000uF	CPOL-USH	PANASONIC_H	0G_RCL	Cornell Dubilie	AFK108M25H32T-F	Mouser	5985-AFK25V1000-F	25V 1000uF, or Panasonic VFK 680uF					
C03	0.1 uF	Chip Cap C1206	C1206	0G_RCL	Kemet	C1206C104K3RACTU	Mouser	80-C1206C104K3R						
C04	0.1 uF	Chip Cap C1206	C1206	0G_RCL	Kemet	C1206C104K3RACTU	Mouser	80-C1206C104K3R						
C05	0.1 uF	Chip Cap C1206	C1206	0G_RCL	Kemet	C1206C104K3RACTU	Mouser	80-C1206C104K3R						
C06	0.1 uF	Chip Cap C1206	C1206	0G_RCL	Kemet	C1206C104K3RACTU	Mouser	80-C1206C104K3R						
C07	0.01 uF	Chip Cap C1206	C1206	0G_RCL	Kemet	C1206C103K3RACTU	Mouser	80-C1206C103K3R						
C08	0.1 uF	Chip Cap C1206	C1206	0G_RCL	Kemet	C1206C104K3RACTU	Mouser	80-C1206C104K3R						
C09	0.1 uF	Chip Cap C1206	C1206	0G_RCL	Kemet	C1206C104K3RACTU	Mouser	80-C1206C104K3R						
C10	0.01 uF	Chip Cap C1206	C1206	0G_RCL	Kemet	C1206C103K3RACTU	Mouser	80-C1206C103K3R						
C11A	180pF	Chip Cap C1210	C1210	0G_Passives	AVX	SQCB9M181JAJME	Digikey	478-2654-1-ND	Must be NPO/COG, 180pF for 6 Meters					
C11B	330pF	Chip Cap C1210	C1210	0G_Passives	AVX	SQCB2M331JAJME	Digikey	478-2660-1-ND	Must be NPO/COG. 330pF for 10 Meters					
C12	0.01 uF	Chip Cap C1206	C1206	0G_RCL	Kemet	C1206C103K3RACTU	Mouser	80-C1206C103K3R						
C13	0.1 uF	Chip Cap C1206	C1206	0G_RCL	Kemet	C1206C104K3RACTU	Mouser	80-C1206C104K3R						
C14	0.1 uF	Chip Cap C1206	C1206	0G_RCL	Kemet	C1206C104K3RACTU	Mouser	80-C1206C104K3R						
C15	0.1 uF	Chip Cap C1206	C1206	0G_RCL	Kemet	C1206C104K3RACTU	Mouser	80-C1206C104K3R						
C16	0.1 uF	Chip Cap C1206	C1206	0G_RCL	Kemet	C1206C104K3RACTU	Mouser	80-C1206C104K3R						
C17	0.1 uF	Chip Cap C1206	C1206	0G_RCL	Kemet	C1206C104K3RACTU	Mouser	80-C1206C104K3R						
C18	0.01 uF	Chip Cap C1206	C1206	0G_RCL	Kemet	C1206C103K3RACTU	Mouser	80-C1206C103K3R						
C19	0.1 uF	Chip Cap C1206	C1206	0G_RCL	Kemet	C1206C104K3RACTU	Mouser	80-C1206C104K3R						
C20	1 uF	Chip Cap C1206	C1206	0G_RCL	Kemet	C1206C105K3RACTU	Mouser	80-C1206C105K3R						
C21	0.1 uF	Chip Cap C1206	C1206	0G_RCL	Kemet	C1206C104K3RACTU	Mouser	80-C1206C104K3R						
C22	0.1 uF	Chip Cap C1206	C1206	0G_RCL	Kemet	C1206C104K3RACTU	Mouser	80-C1206C104K3R						
C23	0.1 uF	Chip Cap C1206	C1206	0G_RCL	Kemet	C1206C104K3RACTU	Mouser	80-C1206C104K3R						
C24	0.1 uF	Chip Cap C1206	C1206	0G_RCL	Kemet	C1206C104K3RACTU	Mouser	80-C1206C104K3R						
C25	100uF	CPOL-USF	PANASONIC_F	0G_RCL	United CC	EMKA250ADA101MHA0G	Mouser	661-MKA25VC101M						
C26	0.1 uF	Chip Cap C1206	C1206	0G_RCL	Kemet	C1206C104K3RACTU	Mouser	80-C1206C104K3R						
J1	3 Pin	0.1 in sq, polarized	MA03-1	0G_Connectors	Molex	22-11-2032	Mouser	538-22-11-2032						
J2	Pwr Conn	KK-MAXI-2 HORIZ	KK-MAXI-2H	0G_DDS-Controller	Molex	26-60-5020	Mouser	538-26-60-5020						
L1	FB-73-801	Ferrite bead	HP-CHOKE	0G_RF_Magnetics	FairRite	FB-73-801	Amidon	FB-73-801						
L2	FB-73-801	Ferrite bead	HP-CHOKE	0G_RF_Magnetics	FairRite	FB-73-801	Amidon	FB-73-801						
L3	FB-73-101	Ferrite bead	LP-CHOKE	0G_RF_Magnetics	FairRite	FB-73-101	Amidon	FB-73-101						
L4	FB-73-101	Ferrite bead	LP-CHOKE	0G_RF_Magnetics	FairRite	FB-73-101	Amidon	FB-73-101						
Q1	RD15VHF1	RF LDMOS FET	TO220HOLE	0G_Mitubishi RF Power	Mitubishi	RD15VHF1	RF Parts	RD15VHF1	Use anti-static precautions					
Q2	RD15VHF1	RF LDMOS FET	TO220HOLE	0G_Mitubishi RF Power	Mitubishi	RD15VHF1	RF Parts	RD15VHF1	May also use RD16HHF1					
Q3	ZVP2106G	P-Chnl MOSFET	SOT223	0G_Regulators	Zetex	ZVP2106GTA	Mouser	522-ZVP2106GTA	Use anti-static precautions					
R01	1	Chip Res R1206	R1206	0G_RCL	Xicon	263-1-RC	Mouser	263-1-RC						
R02	NP	Chip Res R1206	R1206	0G_RCL					Not Populated					
R03	56	Chip Res R1206	R1206	0G_RCL	Xicon	263-56-RC	Mouser	263-56-RC						
R04	56	Chip Res R1206	R1206	0G_RCL	Xicon	263-56-RC	Mouser	263-56-RC						
R05	NP	Chip Res R1206	R1206	0G_RCL					Not Populated					
R06	0	Chip Res R1206	R1206	0G_RCL	Xicon	263-0-RC	Mouser	263-0-RC						
R07	NP	Chip Res R1206	R1206	0G_RCL					Not Populated					
R08	NP	Chip Res R1206	R1206	0G_RCL					Not Populated					

R09	NP	Chip Res R1206	R1206	0G_RCL						Not Populated		
R10	0	Chip Res R1206	R1206	0G_RCL	Xicon	263-0-RC	Mouser	263-0-RC				
R11	2K	TRIMPOT	3362P	0G_Passives	Bourns	3362P-1-202LF	Mouser	652-3362P-1-202LF				
R12	NP	Chip Res R1206	R1206	0G_RCL						Not Populated		
R13	1	Chip Res R1206	R1206	0G_RCL	Xicon	263-1-RC	Mouser	263-1-RC				
R14	1K	Chip Res R1206	R1206	0G_RCL	Xicon	263-1K-RC	Mouser	263-1K-RC				
R15	56	Chip Res R1206	R1206	0G_RCL	Xicon	263-56-RC	Mouser	263-56-RC				
R16	56	Chip Res R1206	R1206	0G_RCL	Xicon	263-56-RC	Mouser	263-56-RC				
R17	2K	TRIMPOT	3362P	0G_Passives	Bourns	3362P-1-202LF	Mouser	652-3362P-1-202LF				
R18	1K	Chip Res R1206	R1206	0G_RCL	Xicon	263-1K-RC	Mouser	263-1K-RC				
R19	10K	Chip Res R1206	R1206	0G_RCL	Xicon	263-10K-RC	Mouser	263-10K-RC				
T1	BN-43-302	Ferrite Xmfr	BN302-2W2T-H	0G_RF_Magnetics	FairRite	BN-43-302	Amidon	BN-43-302		See Construction Notes		
T2	BN-43-202	Ferrite Xmfr	BN302-1W1T	0G_RF_Magnetics	FairRite	BN-43-202	Amidon	BN-43-202		See Construction Notes		
T3	RF-800-4	Ferrite Xmfr	RF-800	0G_RF_Magnetics	CCI	RF-800-4	CCI	RF-800-4				
U1	6V Reg	L78L06_D	SO08	0G_Regulators	STM	L78L06ACD13TR	Mouser	511-L78L06ACD-TR				
X1	BNC	Right Angle Jack	SD-73100	0G_Connectors	Molex	73100-0105	Mouser	538-73100-0105				
X2	BNC	Right Angle Jack	SD-73100	0G_Connectors	Molex	73100-0105	Mouser	538-73100-0105				
==	=====	=====	=====	=====								
Miscellaneous Hardware												
PCB		RX-HPF PCB										
HS		Heat Sink										
Wire for Transformers, 16 inches #24 for T1, and 8 inches of #22 for T2.												
--	#4 by 1/4" standoffs		8 total									
--	6-32 Cap head screws,		2 total									
--	#6 lockwasher		2 total									
--	4-40 Cap head Screws		8 total									
--	#4 lockwashers		8 total									
--	#4 washers		8 total									
--	Mating Connector Body for J2 - KK Maxi				Molex	09-50-3021	Mouser	538-09-50-3021		1 each		
--	Crimp Pins for Mating Connector (2 req'd)				Molex	08-52-0072	Mouser	538-08-52-0072		2 each		
--	Mating Connector Body for J1				Molex	22-01-3037	Mouser	538-22-01-3037		1 each		
--	Crimp Pins for Mating Connector (3 req'd)				Molex	08-65-0816	Mouser	538-08-65-0816		3 each		

Appendix "D"

Special Sort - Recommended Assembly Order

PennyWhistle P1.04 BOM			Assembly Sort	10/31/2009							
Part	Value	Description	Footprint/ Package	Library	Manu	Part No.	Vendor	Part No.	Notes		
C01	0.1 uF	Chip Cap C1206	C1206	0G_RCL	Kemet	C1206C104K3RACTU	Mouser	80-C1206C104K3R			
C03	0.1 uF	Chip Cap C1206	C1206	0G_RCL	Kemet	C1206C104K3RACTU	Mouser	80-C1206C104K3R			
C04	0.1 uF	Chip Cap C1206	C1206	0G_RCL	Kemet	C1206C104K3RACTU	Mouser	80-C1206C104K3R			
C05	0.1 uF	Chip Cap C1206	C1206	0G_RCL	Kemet	C1206C104K3RACTU	Mouser	80-C1206C104K3R			
C06	0.1 uF	Chip Cap C1206	C1206	0G_RCL	Kemet	C1206C104K3RACTU	Mouser	80-C1206C104K3R			
C08	0.1 uF	Chip Cap C1206	C1206	0G_RCL	Kemet	C1206C104K3RACTU	Mouser	80-C1206C104K3R			
C09	0.1 uF	Chip Cap C1206	C1206	0G_RCL	Kemet	C1206C104K3RACTU	Mouser	80-C1206C104K3R			
C13	0.1 uF	Chip Cap C1206	C1206	0G_RCL	Kemet	C1206C104K3RACTU	Mouser	80-C1206C104K3R			
C14	0.1 uF	Chip Cap C1206	C1206	0G_RCL	Kemet	C1206C104K3RACTU	Mouser	80-C1206C104K3R			
C15	0.1 uF	Chip Cap C1206	C1206	0G_RCL	Kemet	C1206C104K3RACTU	Mouser	80-C1206C104K3R			
C16	0.1 uF	Chip Cap C1206	C1206	0G_RCL	Kemet	C1206C104K3RACTU	Mouser	80-C1206C104K3R			
C17	0.1 uF	Chip Cap C1206	C1206	0G_RCL	Kemet	C1206C104K3RACTU	Mouser	80-C1206C104K3R			
C19	0.1 uF	Chip Cap C1206	C1206	0G_RCL	Kemet	C1206C104K3RACTU	Mouser	80-C1206C104K3R			
C21	0.1 uF	Chip Cap C1206	C1206	0G_RCL	Kemet	C1206C104K3RACTU	Mouser	80-C1206C104K3R			
C22	0.1 uF	Chip Cap C1206	C1206	0G_RCL	Kemet	C1206C104K3RACTU	Mouser	80-C1206C104K3R			
C23	0.1 uF	Chip Cap C1206	C1206	0G_RCL	Kemet	C1206C104K3RACTU	Mouser	80-C1206C104K3R			
C24	0.1 uF	Chip Cap C1206	C1206	0G_RCL	Kemet	C1206C104K3RACTU	Mouser	80-C1206C104K3R			
C26	0.1 uF	Chip Cap C1206	C1206	0G_RCL	Kemet	C1206C104K3RACTU	Mouser	80-C1206C104K3R			
C07	0.01 uF	Chip Cap C1206	C1206	0G_RCL	Kemet	C1206C103K3RACTU	Mouser	80-C1206C103K3R			
C10	0.01 uF	Chip Cap C1206	C1206	0G_RCL	Kemet	C1206C103K3RACTU	Mouser	80-C1206C103K3R			
C12	0.01 uF	Chip Cap C1206	C1206	0G_RCL	Kemet	C1206C103K3RACTU	Mouser	80-C1206C103K3R			
C18	0.01 uF	Chip Cap C1206	C1206	0G_RCL	Kemet	C1206C103K3RACTU	Mouser	80-C1206C103K3R			
C20	1 uF	Chip Cap C1206	C1206	0G_RCL	Kemet	C1206C105K3RACTU	Mouser	80-C1206C105K3R			
C11A	180pF	Chip Cap C1210	C1210	0G_Passives	AVX	SQCB9M181JAJME	Digikey	478-2654-1-ND	Use 180pF for 6 Meters, or		
C11B	330pF	Chip Cap C1210	C1210	0G_Passives	AVX	SQCB2M331JAJME	Digikey	478-2660-1-ND	Use 330pF for 10 Meters		
R06	0	Chip Res R1206	R1206	0G_RCL	Xicon	263-0-RC	Mouser	263-0-RC			
R10	0	Chip Res R1206	R1206	0G_RCL	Xicon	263-0-RC	Mouser	263-0-RC			
R01	1	Chip Res R1206	R1206	0G_RCL	Xicon	263-1-RC	Mouser	263-1-RC			
R13	1	Chip Res R1206	R1206	0G_RCL	Xicon	263-1-RC	Mouser	263-1-RC			
R03	56	Chip Res R1206	R1206	0G_RCL	Xicon	263-56-RC	Mouser	263-56-RC			
R04	56	Chip Res R1206	R1206	0G_RCL	Xicon	263-56-RC	Mouser	263-56-RC			
R15	56	Chip Res R1206	R1206	0G_RCL	Xicon	263-56-RC	Mouser	263-56-RC			
R16	56	Chip Res R1206	R1206	0G_RCL	Xicon	263-56-RC	Mouser	263-56-RC			
R14	1K	Chip Res R1206	R1206	0G_RCL	Xicon	263-1K-RC	Mouser	263-1K-RC			
R18	1K	Chip Res R1206	R1206	0G_RCL	Xicon	263-1K-RC	Mouser	263-1K-RC			
R19	10K	Chip Res R1206	R1206	0G_RCL	Xicon	263-10K-RC	Mouser	263-10K-RC			
R02	NP	Chip Res R1206	R1206	0G_RCL					Not Populated		
R05	NP	Chip Res R1206	R1206	0G_RCL					Not Populated		
R07	NP	Chip Res R1206	R1206	0G_RCL					Not Populated		
R08	NP	Chip Res R1206	R1206	0G_RCL					Not Populated		
R09	NP	Chip Res R1206	R1206	0G_RCL					Not Populated		
R12	NP	Chip Res R1206	R1206	0G_RCL					Not Populated		
Q3	ZVP2106G	P-Chnl MOSFET	SOT223	0G_Regulators	Zetex	ZVP2106GTA	Mouser	522-ZVP2106GTA	Use anti-static precautions		

U1	6V Reg	L78L06_D	SO08	0G_Regulators	STM	L78L06ACD13TR	Mouser	511-L78L06ACD-TR	Observe orientation	
									Use anti-static precautions	
C25	100uF	CPOL-USF	PANASONIC_F	0G_RCL	United CC	EMKA250ADA101MHA0G	Mouser	661-MKA25VC101M		
C02	1000uF	CPOL-USH	PANASONIC_H	0G_RCL	Cornell Dubilier	AFK108M25H32T-F	Mouser	5985-AFK25V1000-F		
J1	3 Pin	0.1 in sq, polarized	MA03-1	0G_Connectors	Molex	22-11-2032	Mouser	538-22-11-2032	Observe orientation	
J2	Pwr Conn	KK-MAXI-2 HORIZ	KK-MAXI-2H	0G_DDS-Controller	Molex	26-60-5020	Mouser	538-26-60-5020		
R11	2K	TRIMPOT	3362P	0G_Passives	Bourns	3362P-1-202LF	Mouser	652-3362P-1-202LF		
R17	2K	TRIMPOT	3362P	0G_Passives	Bourns	3362P-1-202LF	Mouser	652-3362P-1-202LF		
L1	FB-73-801	Ferrite bead	HP-CHOKE	0G_RF_Magnetics	FairRite	FB-73-801	Amidon	FB-73-801	See Appendix "E"	
L2	FB-73-801	Ferrite bead	HP-CHOKE	0G_RF_Magnetics	FairRite	FB-73-801	Amidon	FB-73-801	See Appendix "E"	
L3	FB-73-101	Ferrite bead	LP-CHOKE	0G_RF_Magnetics	FairRite	FB-73-101	Amidon	FB-73-101	See Appendix "E"	
L4	FB-73-101	Ferrite bead	LP-CHOKE	0G_RF_Magnetics	FairRite	FB-73-101	Amidon	FB-73-101	See Appendix "E"	
T1	BN-43-302	Ferrite Xmfr	BN302-2W2T-H	0G_RF_Magnetics	FairRite	BN-43-302	Amidon	BN-43-302	See Appendix "E"	
T2	BN-43-202	Ferrite Xmfr	BN302-1W1T	0G_RF_Magnetics	FairRite	BN-43-202	Amidon	BN-43-202	See Appendix "E"	
T3	RF-800-4	Ferrite Xmfr	RF-800	0G_RF_Magnetics	CCI	RF-800-4	CCI	RF-800-4		
X1	BNC	Right Angle Jack	SD-73100	0G_Connectors	Molex	73100-0105	Mouser	538-73100-0105		
X2	BNC	Right Angle Jack	SD-73100	0G_Connectors	Molex	73100-0105	Mouser	538-73100-0105		
Q1	RD15VHF1	RF LDMOS FET	TO220HOLE	0G_Mitubishi RF Power	Mitubishi	RD15VHF1	RF Parts	RD15VHF1	Use anti-static precautions	
Q2	RD15VHF1	RF LDMOS FET	TO220HOLE	0G_Mitubishi RF Power	Mitubishi	RD15VHF1	RF Parts	RD15VHF1	May also use RD16HHF1	
									See Appendix "F"	

Appendix "E"

Inductors, and Instructions for Winding the Transformers

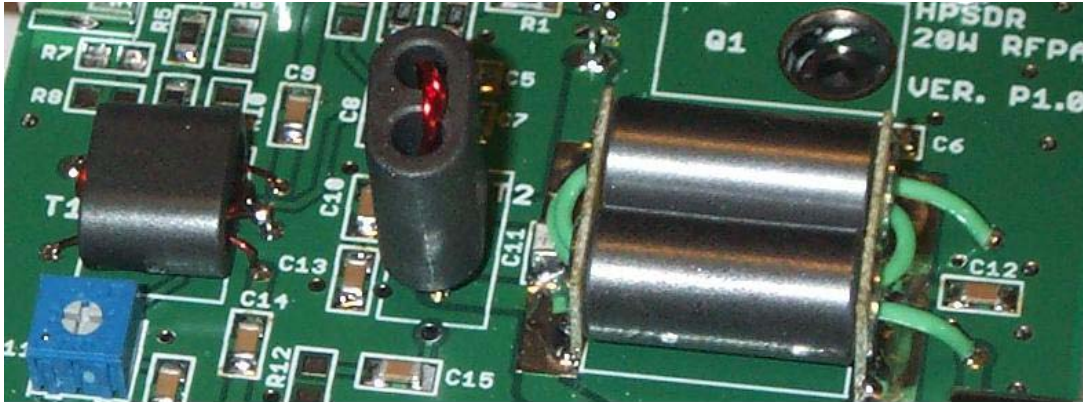

Note 1: When dealing with a binocular core, the definition of one turn, is a wire that passes once through each of the two holes. For two turns, the wire would pass through the hole on each side twice. The green wire in the output transformer above is “two turns.”

Note 2: The binocular cores are constructed of ferrite, a type of hard ceramic-like material containing iron. They are formed in molds, and sometimes there are sharp edges, called “mold parting lines” at the entrance edges of the holes at each end, that will scrape the insulation off of an enamel insulated wire, when it is pulled through the hole. Prior to winding, use the tip of a knife blade, or something abrasive to smooth the entrance edge of each hole in the core. This is not necessary for the pre-assembled output transformer.

T1 is constructed using an Amidon/Fair-Rite BN43-302 “short” binocular core. The primary is two turns #24 wire. The secondary is one turn, #24, bifilar twisted pair, wired as two turns center tapped. The target input impedance is 50 ohms across the primary. The target secondary output load is 50 ohms across the outer leads, or 25 Ohms center tap to each outside lead..

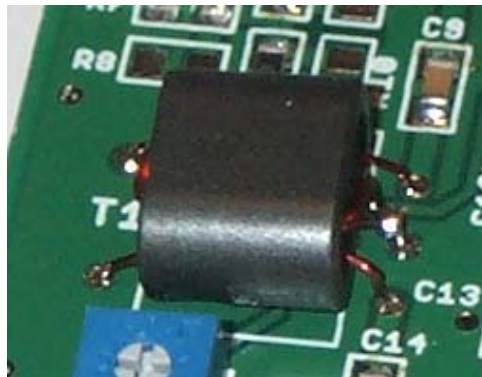

To construct the transformer, use the “short” binocular core. Install the secondary first. Take two pieces of #24 insulated transformer wire, about four inches long, and twist them together, about five or six half-twists per inch. Bend it into a “U”, and pass each side through one hole in the core. Cut, strip, and connect the wires so that you end up with a two turn coil that is center tapped.

For the primary side, take about 6 inches of #24 wire, and pass it through the binocular core, passing through the hole on each side twice.

Refer to the connection diagram on the following page.

T2 is constructed using an Amidon/Fair-Rite BN-43-202 binocular core, with one turn #22 bifilar twisted pair wired as a two turn center tapped auto transformer. Winding and connection is similar to the winding of the secondary in transformer T1. Refer to the connection diagram on the following page.

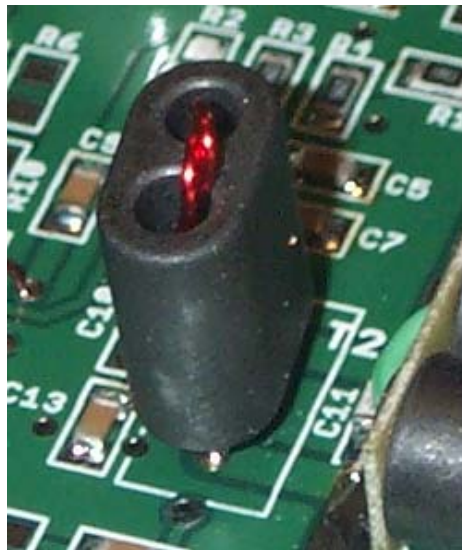

This transformer is used for parallel DC feed, and to enforce side to side balance in the PA. This transformer forces side to side symmetry in the push pull output pair, since there is negligible coupling between the windings in the two different holes in the output binocular transformer.

For normal operation of the PennyWhistle RF Power Amplifier, the additional feedback winding, shown on the schematic, along with R2, R12, and C8 and C15 are not used. If you want to experiment with running this amplifier at lower power levels using negative feedback, and additional resulting linearity, the additional through-holes in the PCB for the feedback winding, and parts locations are provided.

PENNYWHISTLE TRANSFORMER DIAGRAM

T1

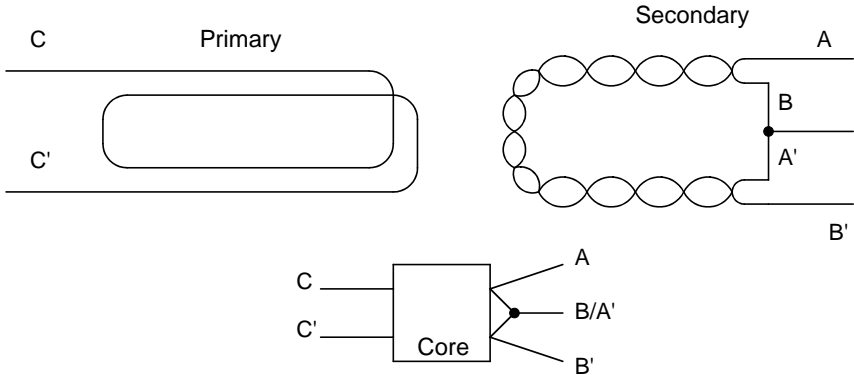

-
- Note 1.) A' is the far end of wire A, B' is far end of wire B, etc.
 - Note 2.) Use an Ohm Meter to figure out which wire is A' and B'
 - Note 3.) Solder B/A' together close to the transformer, so that only one wire goes through the hole in the PCB
-

T2

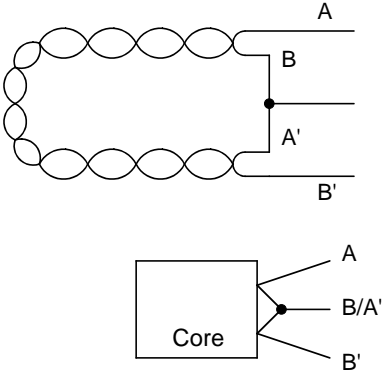

T3 is the output transformer, and is provided pre-wound and preassembled. It is soldered onto the PCB at the exposed solder trace areas. The output wires should be cut to length and connected as pictured.

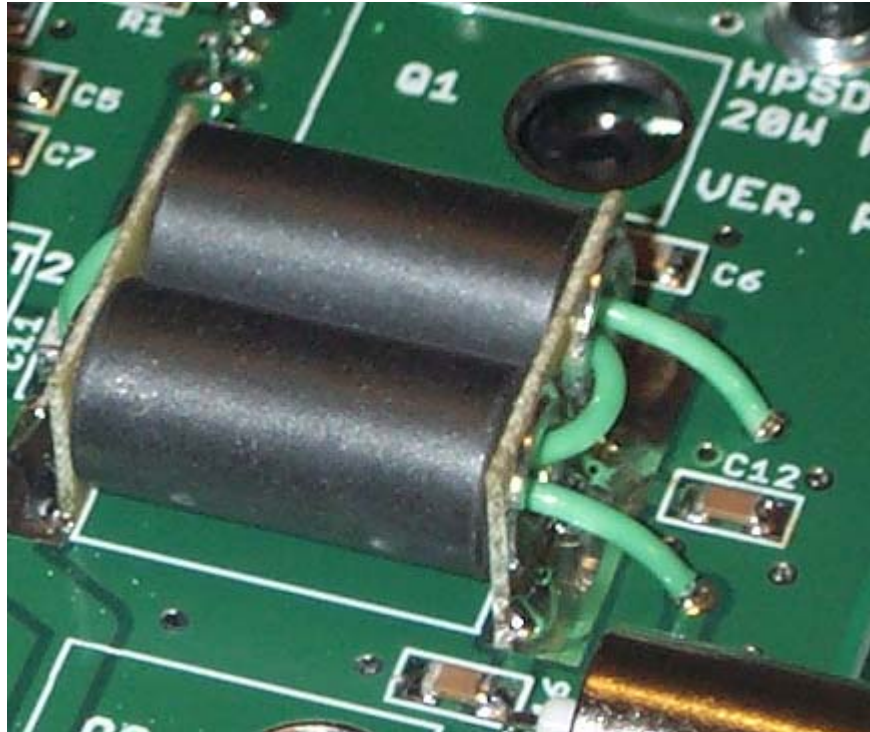

The target operating impedance is 12.5 Ohms across the primary (6.25 Ohms on each side to center) with a 50 Ohm secondary.

The transformer tuning capacitor, C11 is soldered to the main PCB in front of the primary side of T3. It will much easier to install C11 prior to installing T3, rather than afterwards. Refer to the parts location diagram for the location of the capacitor. There is not an obvious white silk-screen marking for this capacitor.

L1, L2, L3, and L4

are single turn passes through the center of the ferrite beads. Use the largest hook-up wire that you have, that will fit comfortably through the respective holes in the PC board.

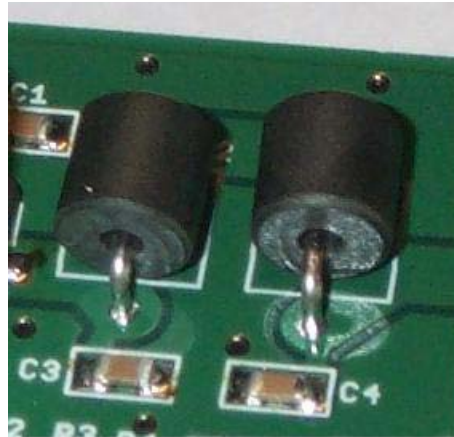

L1 and L2 are the larger beads



L3 and L4 are the smaller beads.

Appendix "F"

Mechanical and PA Transistor Assembly.

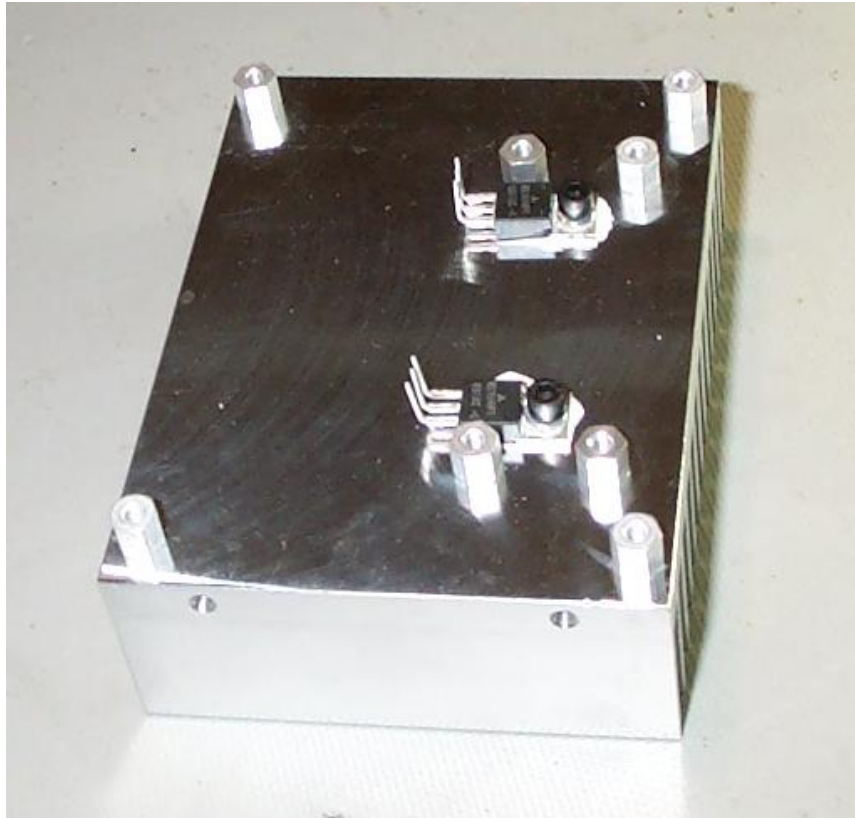

NOTE: Observe anti static handling procedures for the output transistors. These are insulated gate FET transistors, and they can be damaged by static electricity.

Use your fingers to screw and tighten the ¼ inch standoffs into the heat sink. Do not use a wrench or nut driver, as you may over tighten the small #4 screw studs.

The transistors are mounted on the heatsink below the PC board, the leads are bent upwards at the natural bending point where the leads neck down about 0.2 inches or about 3 mm from the edge of the plastic package. A small amount of heatsink compound applied between the heatsink and the metal tab on the transistors will improve heat transfer to the heatsink. When the PCB is mounted to the short studs alongside the transistors, the transistor leads will stick through their respective holes and can be soldered from the top of the board.

In the future, if it necessary to remove the PCB from the heatsink, it is not necessary to unsolder the transistors, since an access hole has been provided for the transistor mounting screws in the PCB.