

ALEX-TX
 VERSION P-1.1
 2011 MAR 27

Copyright 2008-2011, Graham Haddock, KE9H
 and Phil Harman, VK6APH.

Released under TAPR Non-Commercial
 Hardware License

<http://www.tapr.org/NCL>

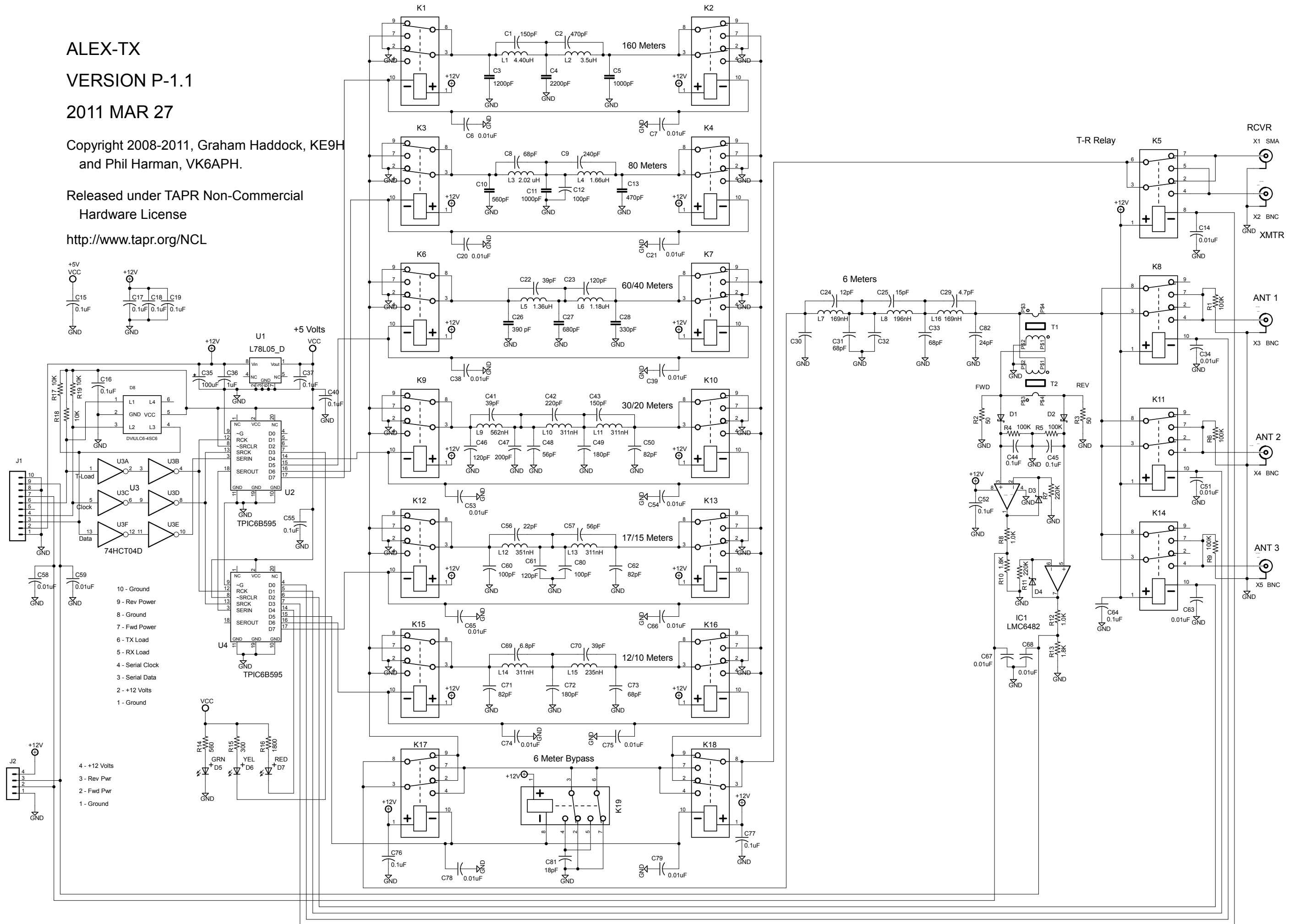

- 10 - Ground
- 9 - Rev Power
- 8 - Ground
- 7 - Fwd Power
- 6 - TX Load
- 5 - RX Load
- 4 - Serial Clock
- 3 - Serial Data
- 2 - +12 Volts
- 1 - Ground

- 4 - +12 Volts
- 3 - Rev Pwr
- 2 - Fwd Pwr
- 1 - Ground