

Revision History

| Date | Revision | By | Description |
|-------------|----------|--------|--|
| 28 Jan 2008 | XA0 | WA2DFI | Initial drawing from VK6APH, KK7P and N8VB versions |
| 29 Jan 2008 | XA1 | WA2DFI | Multiple revisions |
| 24 Feb 2008 | XA3 | KK7P | Added Copyright notices |
| 15 Mar 2008 | XA4 | WA2DFI | Swap pins on J4, J13; add PTC on +12V; add res to DATA1 line |
| 01 Apr 2008 | XA5 | KK7P | Multiple revisions |
| 07 Apr 2008 | XA6 | WA2DFI | Cosmetic and part number revisions only |
| 03 Jun 2008 | XA7 | WA2DFI | Change input XFMR to TC4-1T Add: LPF, preamp bypass, osc pwr disconnect jumpers, SPI series termination Remove: LTC2208 mode option resistors, 122.88MHz clock trace to FPGA, dig ground at shield |
| 07 Jun 2008 | XA8 | WA2DFI | Add: decoupling to U2, U4, U5, U6 Add: clamp on Atlas C16 Change preamp bypass |
| 09 Jun 2008 | XA9 | KK7P | Add Relay Driver, tie grounds at U5, modify LPF at preamp. |
| 20 Jun 2008 | XA10 | KK7P | Modify bypass at preamp. |
| 25 Jul 2008 | XA11 | KK7P | Revise preamp, add ATTN/LPF/Relay to front end. |
| 31 Jul 2008 | XA12 | WA2DFI | Update R49, R50, R51, FL1, K1 properties. No electrical changes. |
| 21 Sep 2008 | A | KK7P | Production Release: K1 power change, add C97 - C99. |

Copyright 2008, Phil Harman, VK6APH and Lyle Johnson, KK7P.
 Derived from work by Phil Covington, N8VB.
 Released under TAPR Non-commercial Hardware License.
<http://www.tapr.org/NCL>

| | | |
|--------------------------------------|-----------------------------|----------|
| Title HPSDR Mercury: Power Supply | | |
| Size B | Document Number 20080121 | Rev A |
| Date: Sunday, September 21, 2008 | Sheet 1 | of 8 |

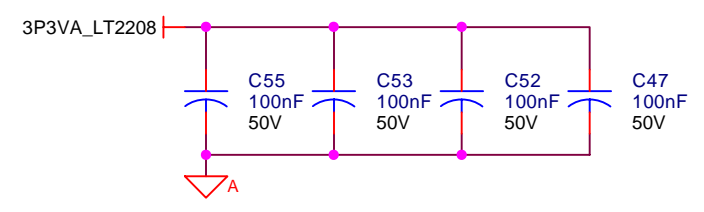
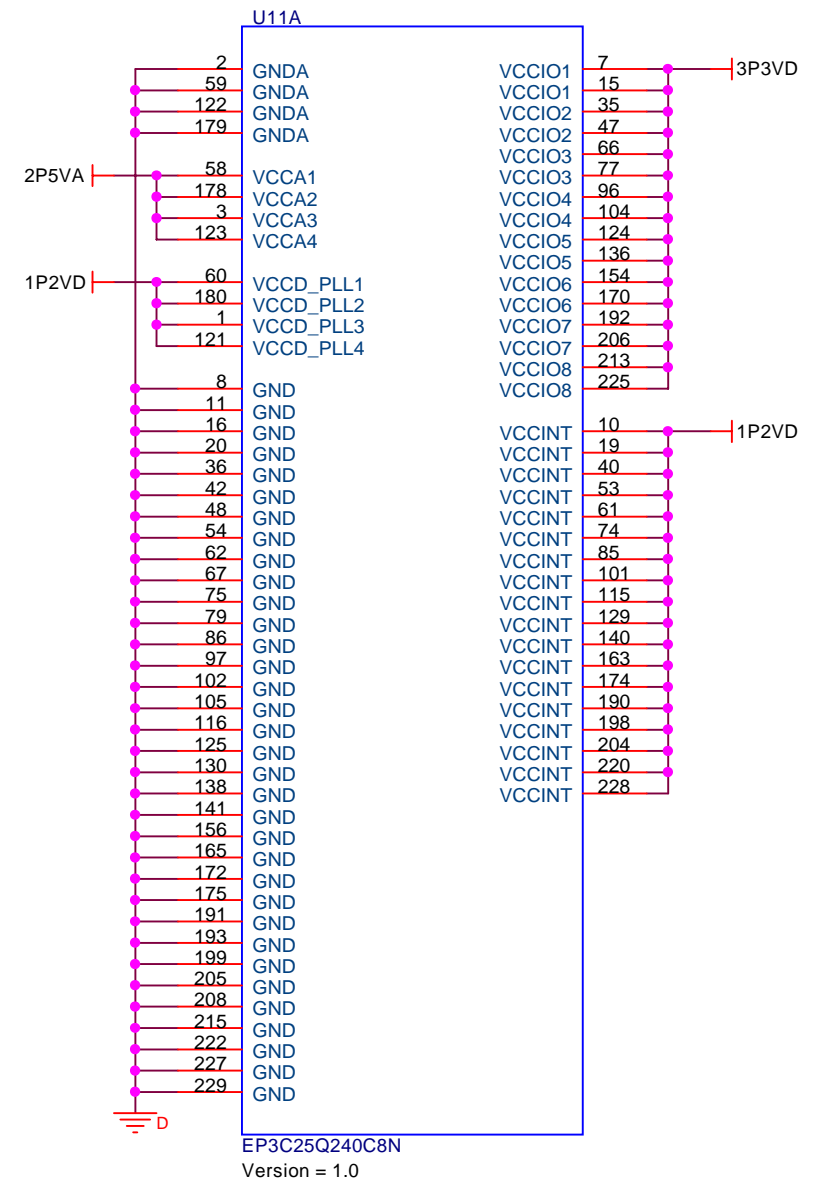
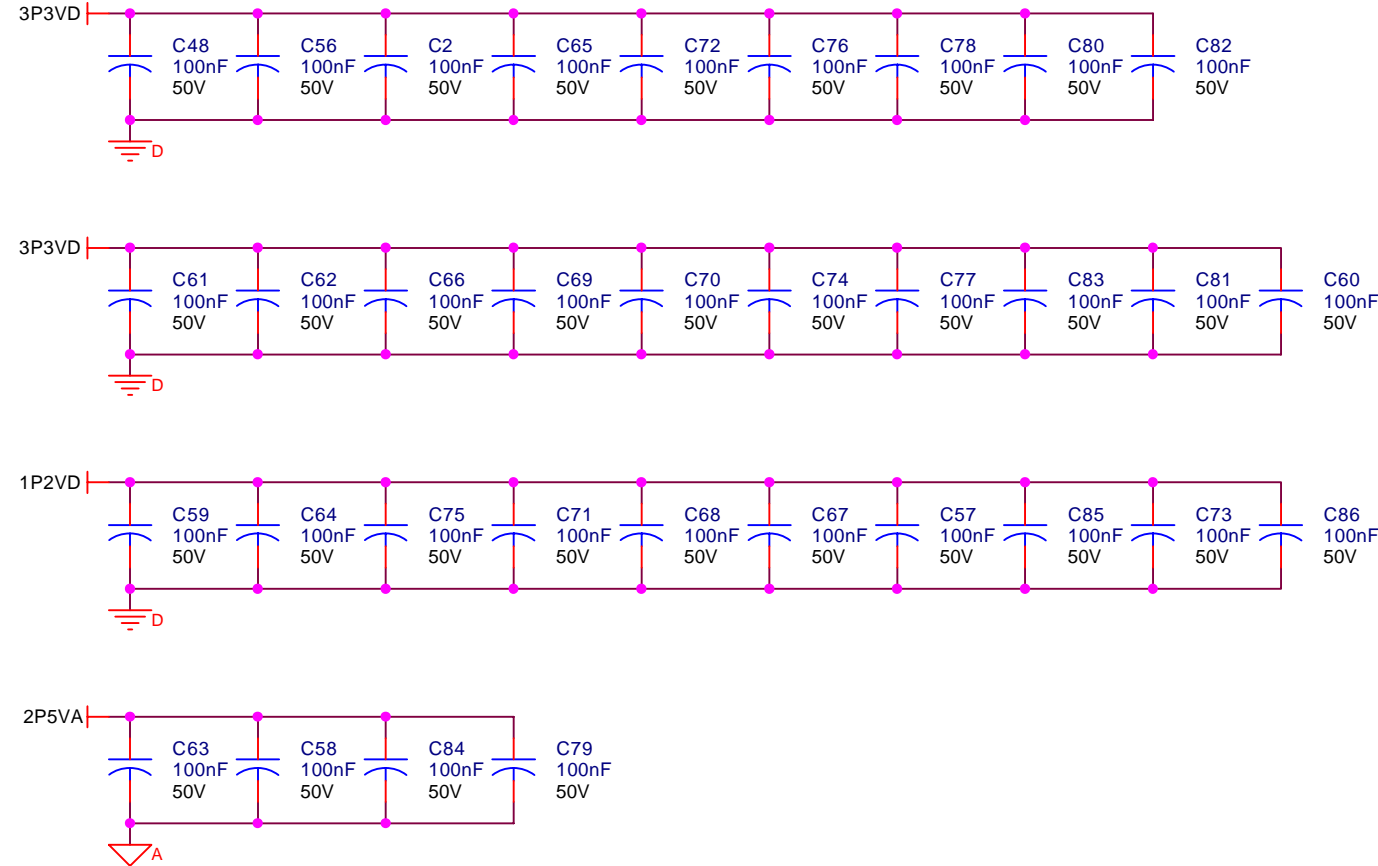

Copyright 2008, Phil Harman, VK6APH and Lyle Johnson, KK7P.
 Derived from work by Phil Covington, N8VB.
 Released under TAPR Non-commercial Hardware License.
<http://www.tapr.org/NCL>

| | | |
|--------------------------------------|----------------------------|--------------|
| Title | | |
| HPSDR Mercury: Bypass and FPGA Power | | |
| Size | Document Number | Rev |
| B | 20080121 | A |
| Date: | Sunday, September 21, 2008 | Sheet 2 of 8 |

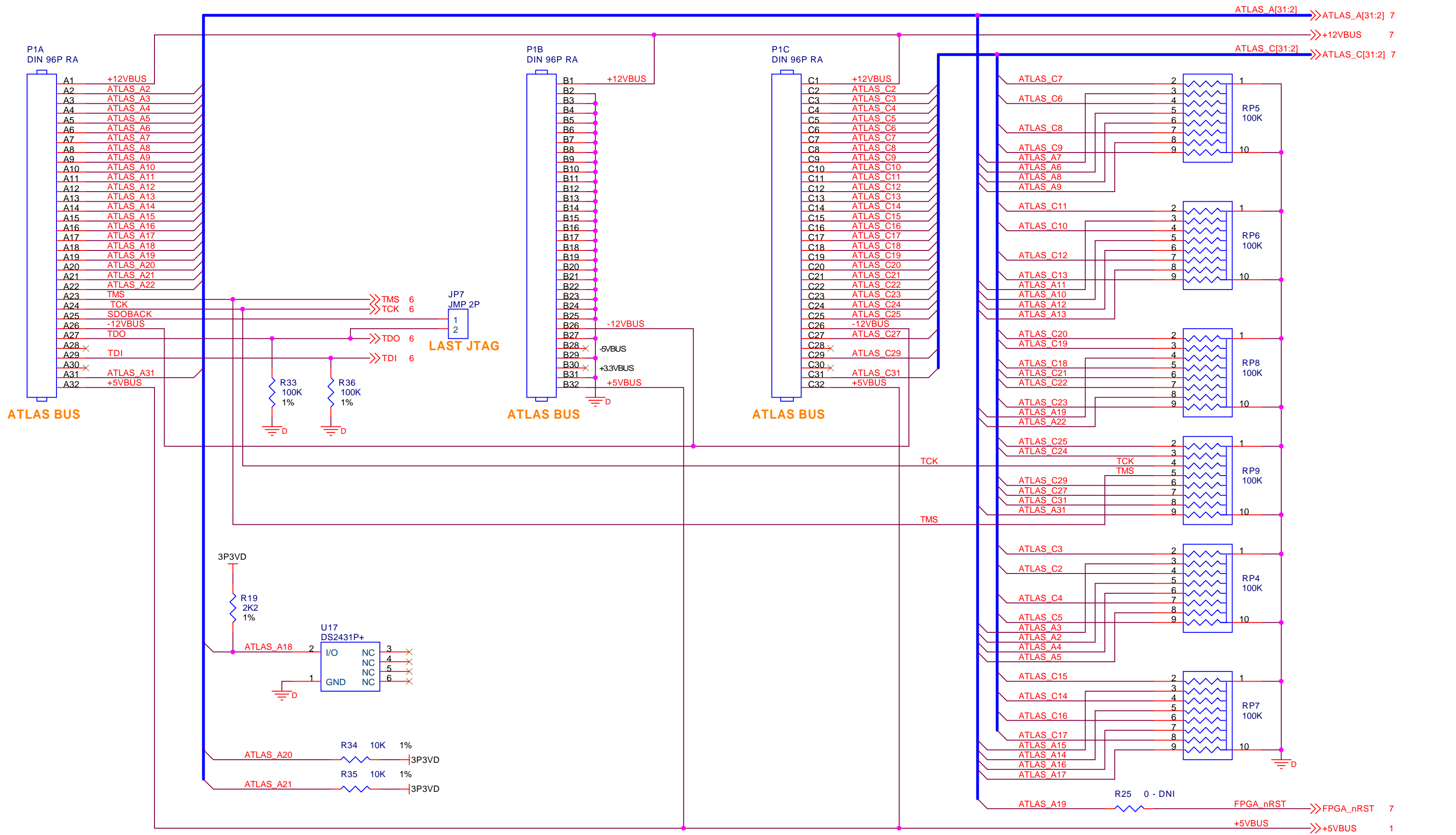

Copyright 2008, Phil Harman, VK6APH and Lyle Johnson, KK7P.
 Derived from work by Phil Covington, N8VB.
 Released under TAPR Non-commercial Hardware License.
<http://www.tapr.org/NCL>

| | | |
|---|-----------------------------|----------|
| Title HPSDR Mercury: Atlas Connector | | |
| Size B | Document Number 20080121 | Rev A |
| Date: Sunday, September 21, 2008 | Sheet 3 | of 8 |

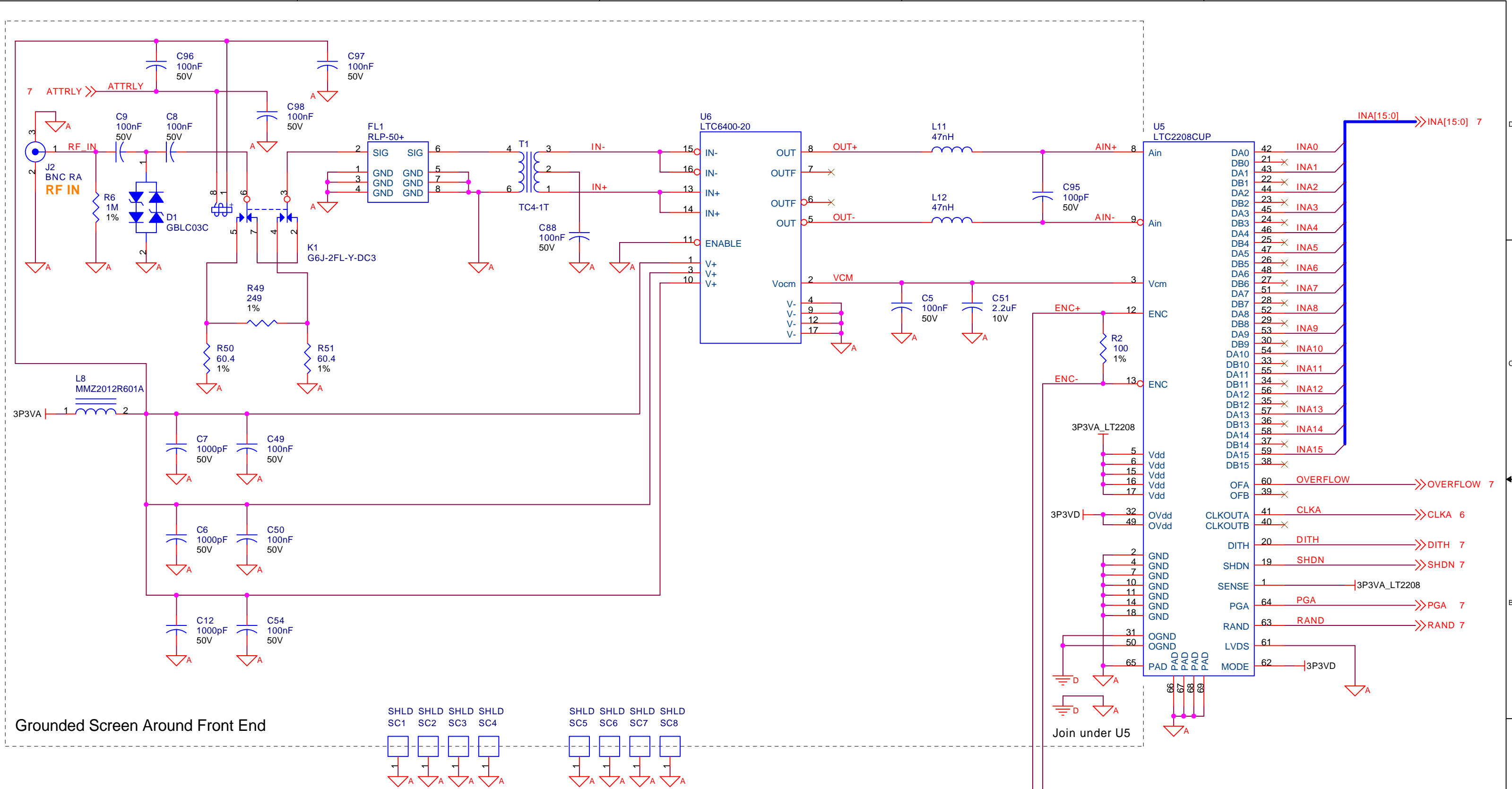

Grounded Screen Around Front End

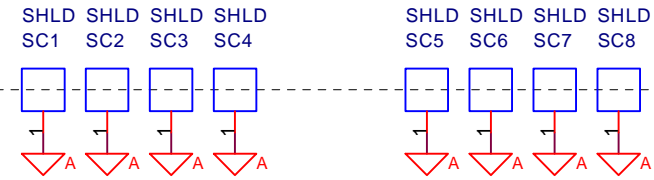

Copyright 2008, Phil Harman, VK6APH and Lyle Johnson, KK7P.
 Derived from work by Phil Covington, N8VB.
 Released under TAPR Non-commercial Hardware License.
<http://www.tapr.org/NCL>

| | | |
|--------------------------|----------------------------|--------------|
| Title | | |
| HPSDR Mercury: Front End | | |
| Size | Document Number | Rev |
| B | 20080121 | A |
| Date: | Thursday, October 16, 2008 | Sheet 4 of 8 |

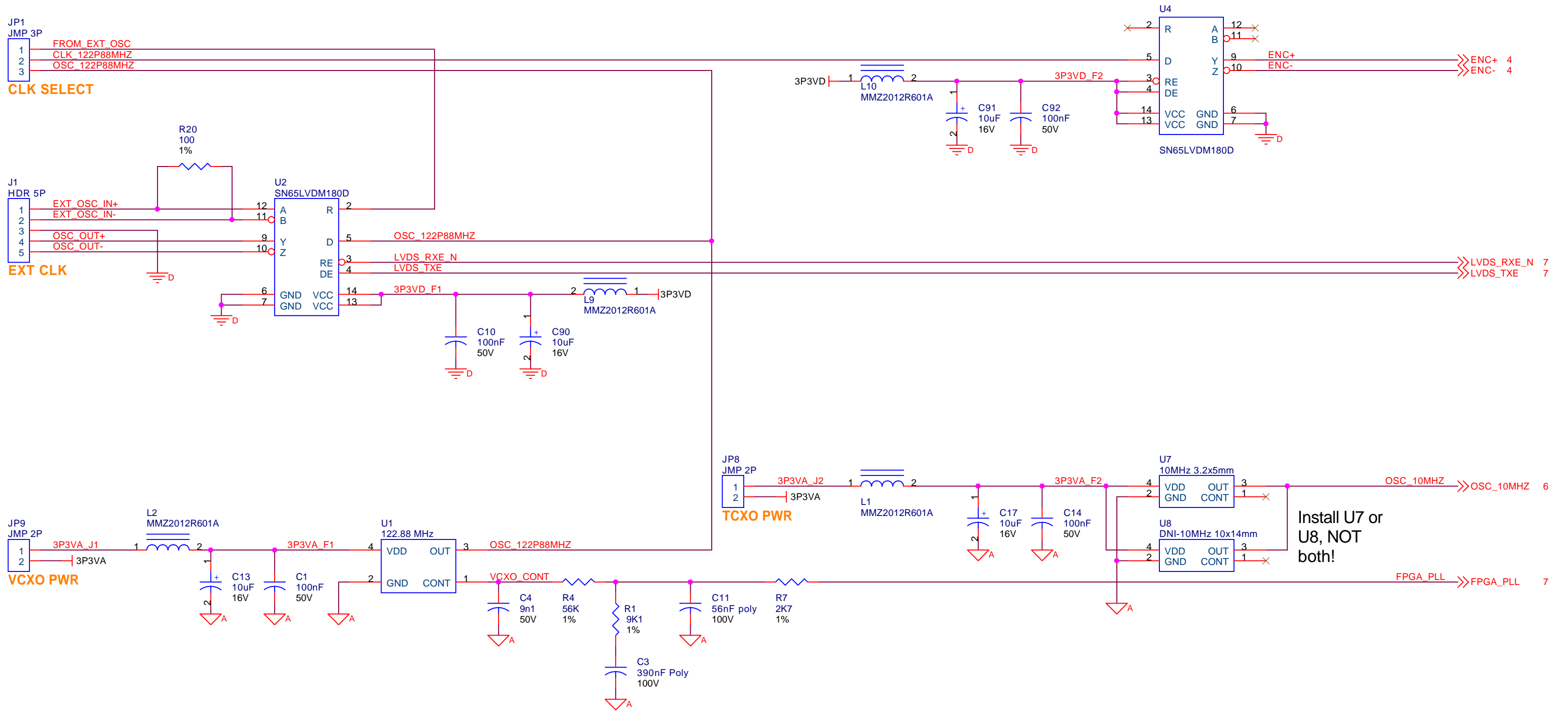

Install U7 or U8, NOT both!

Copyright 2008, Phil Harman, VK6APH and Lyle Johnson, KK7P.
 Derived from work by Phil Covington, N8VB.
 Released under TAPR Non-commercial Hardware License.
<http://www.tapr.org/NCL>

| | | |
|-----------------------|----------------------------|--------------|
| Title | | |
| HPSDR Mercury: Clocks | | |
| Size | Document Number | Rev |
| B | 20080121 | A |
| Date: | Sunday, September 21, 2008 | Sheet 5 of 8 |

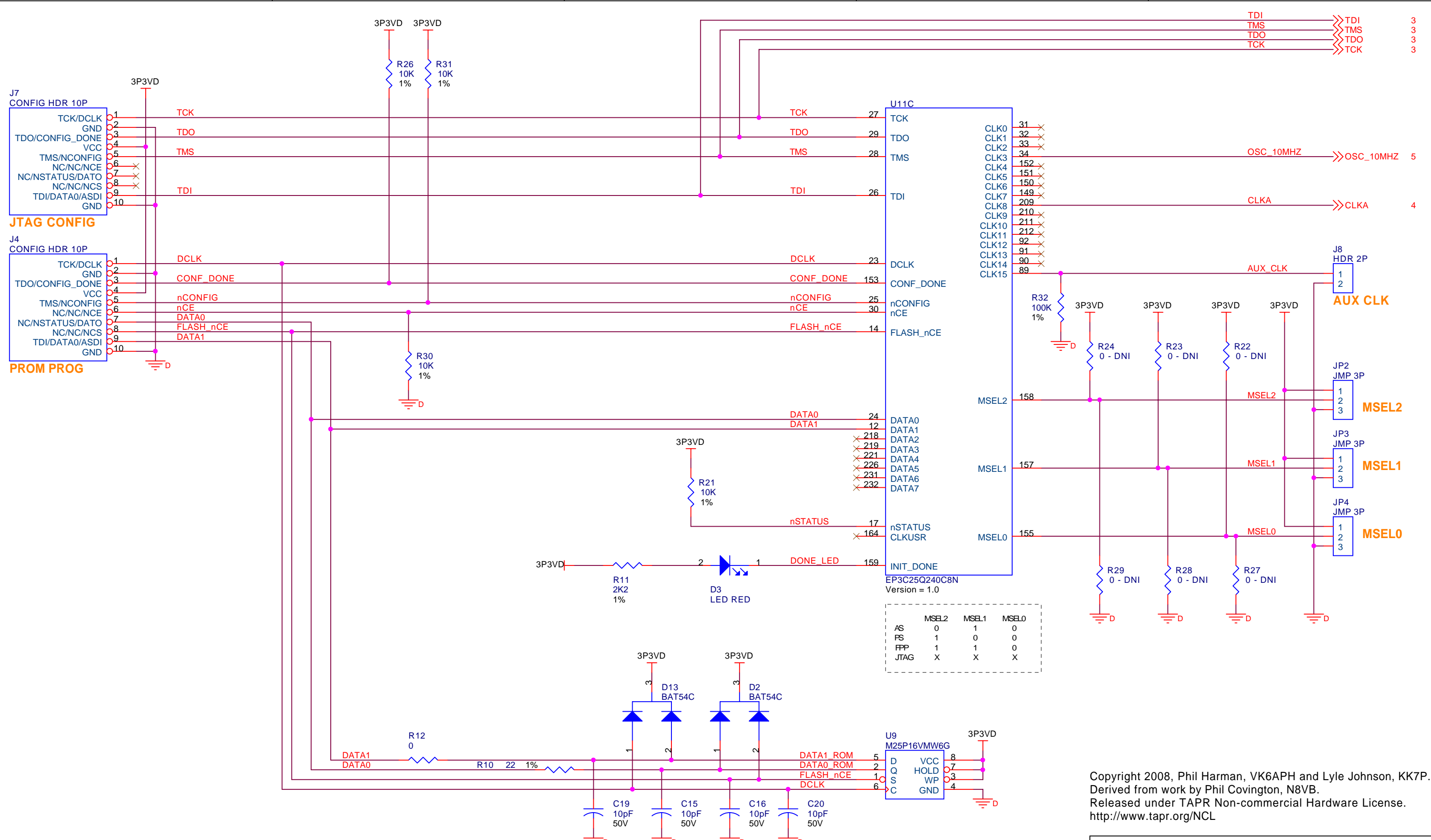

| | MSEL2 | MSEL1 | MSEL0 |
|------|-------|-------|-------|
| AS | 0 | 1 | 0 |
| FS | 1 | 0 | 0 |
| FPP | 1 | 1 | 0 |
| JTAG | X | X | X |

Copyright 2008, Phil Harman, VK6APH and Lyle Johnson, KK7P.
 Derived from work by Phil Covington, N8VB.
 Released under TAPR Non-commercial Hardware License.
<http://www.tapr.org/NCL>

| | | |
|--|-----------------------------|----------|
| Title HPSDR Mercury: FPGA Configuration | | |
| Size B | Document Number 20080121 | Rev A |
| Date: Sunday, September 21, 2008 | Sheet 6 | of 8 |

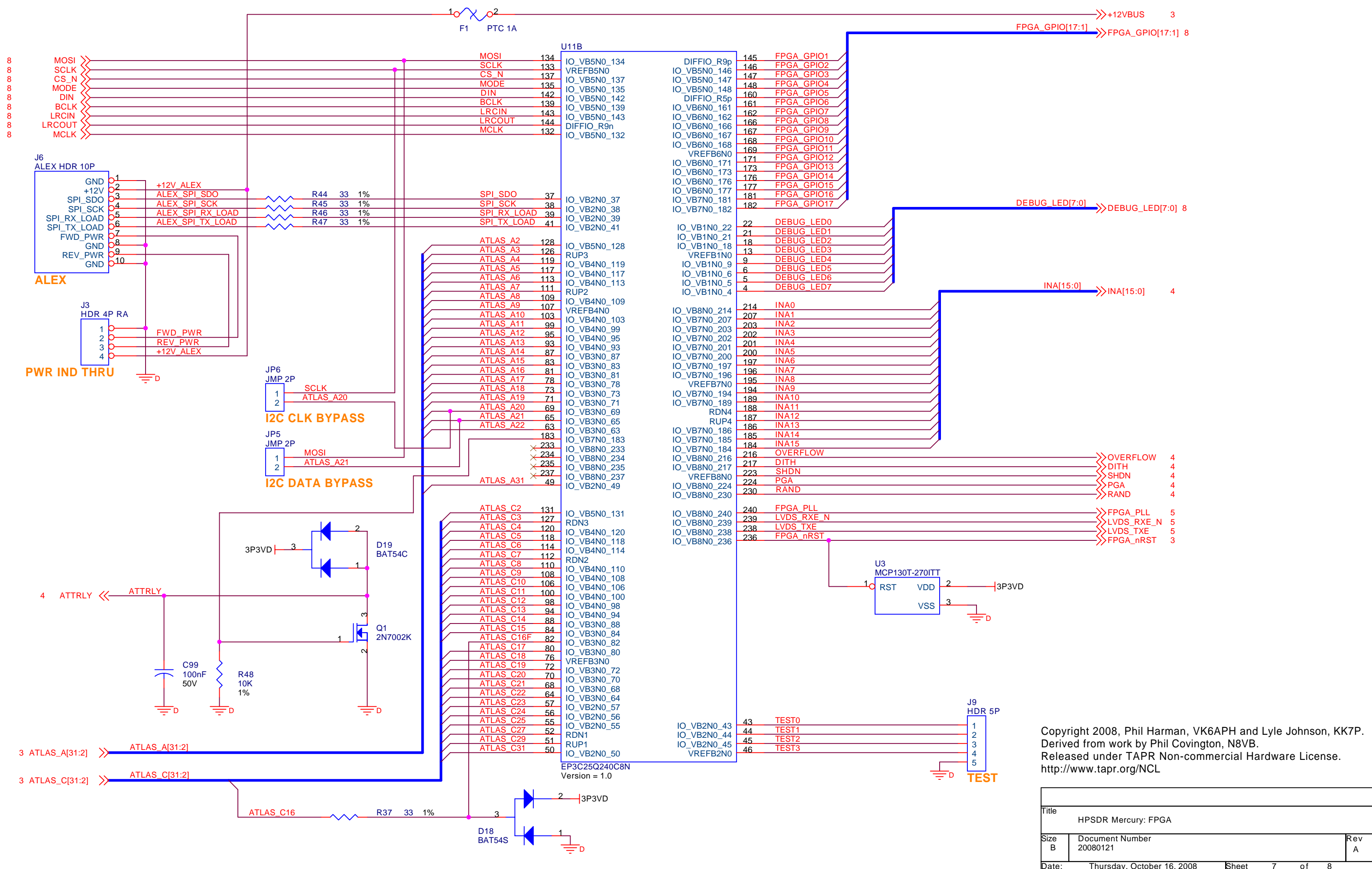

Copyright 2008, Phil Harman, VK6APH and Lyle Johnson, KK7P.
 Derived from work by Phil Covington, N8VB.
 Released under TAPR Non-commercial Hardware License.
<http://www.tapr.org/NCL>

| | | |
|---------------------|----------------------------|--------------|
| Title | | |
| HPSDR Mercury: FPGA | | |
| Size | Document Number | Rev |
| B | 20080121 | A |
| Date: | Thursday, October 16, 2008 | Sheet 7 of 8 |

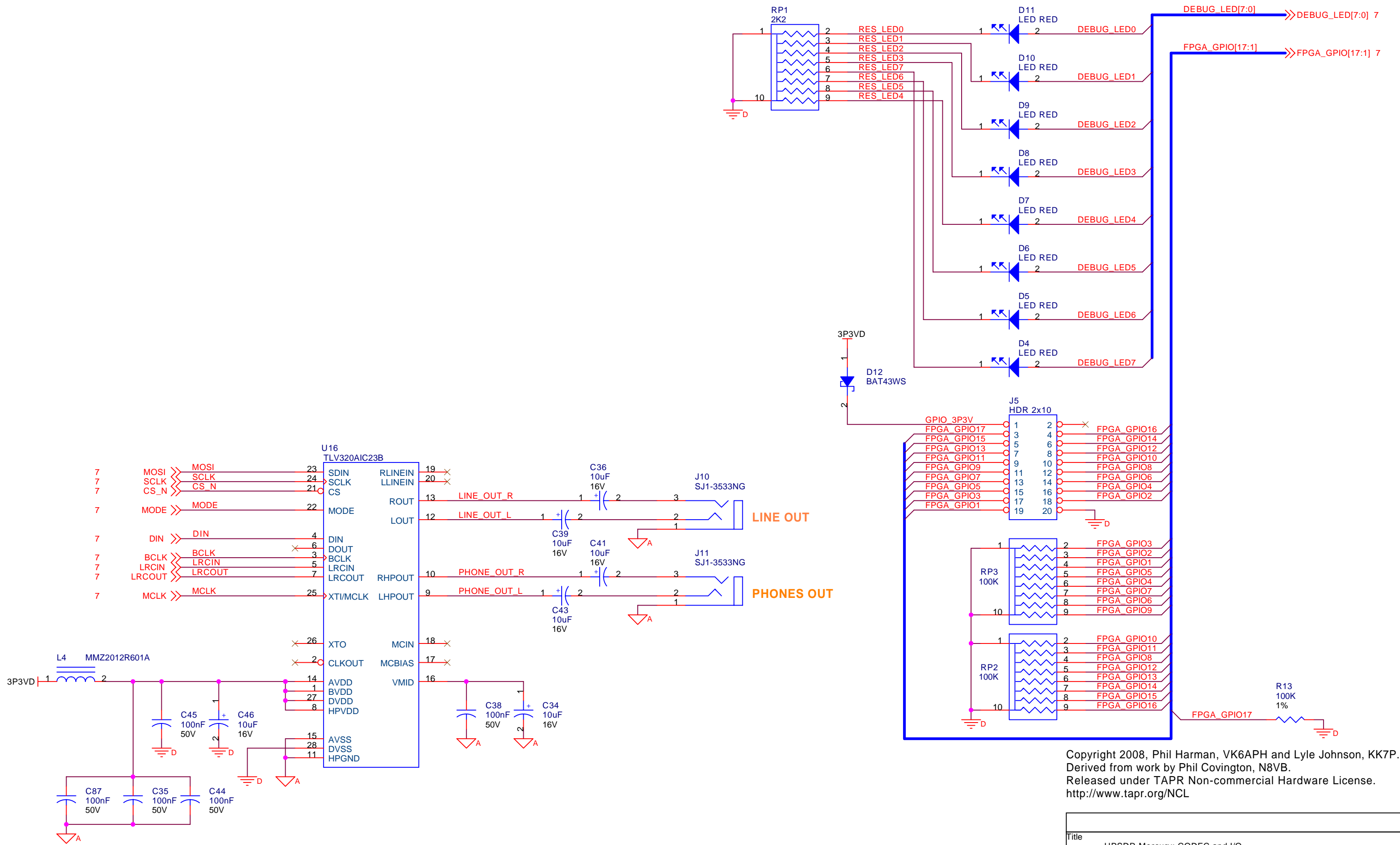

Copyright 2008, Phil Harman, VK6APH and Lyle Johnson, KK7P.
 Derived from work by Phil Covington, N8VB.
 Released under TAPR Non-commercial Hardware License.
<http://www.tapr.org/NCL>

| | | |
|------------------------------|----------------------------|--------------|
| Title | | |
| HPSDR Mercury: CODEC and I/O | | |
| Size | Document Number | Rev |
| B | 20080121 | A |
| Date: | Sunday, September 21, 2008 | Sheet 8 of 8 |